

A 3D architectural rendering of a room layout, showing walls and floor. A circular inset provides a close-up view of the underfloor heating mat, which consists of a grid of heating wires on a white substrate.

Webtech HP (200W) Underfloor Heating System

V4

**MAT HEATING SYSTEM
INSTALLATION MANUAL**

CONTENTS

1	General
1.1	Heating mat system terminology
2	Cautions
3	Scope of supply
3.1	The heating mats
4	Electrical safety and wall preparation
4.1	Electrical boxes and trunking
5	Installation process
5.1	Floor preparation
5.2	Testing the mats
5.3	Important information before laying the mats
5.4	Laying the mats
5.5	Installing the conduit and floor sensor cable
6	Wiring the Webtech-HP system
6.1	Use of contactors
7	Floor types
8	Switching system on and maintenance
9	Troubleshooting
10	Warranty Details
11	Mat specification & resistance
12	Mat resistance and insulation test log
13	Warranty Certificate
14	The plan of the premises

Thank you for choosing our ultra-thin Webtech-HP underfloor heating system. We are pleased to provide you with our product which will bring comfort in your home.

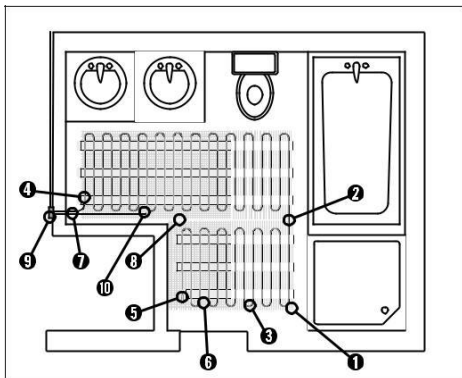

1. GENERAL

Please carefully read this manual before starting the installation of your Webtech-HP underfloor heating system. It will ensure a smooth installation process and a correctly installed system. Incorrect installations may damage the system/flooring and will invalidate the product warranty.

This manual gives installation instructions on how to install under common types of tiles. However, as there are so many variations on the market, it is advised that you contact your flooring manufacturer for advice on installing over underfloor heating. This advice should include suitability of floor covering for underfloor heating, subfloor preparation, insulation, maximum temperature as well as any other general requirements of the manufacturers.

1.1 System application

The following terms will appear frequently throughout this manual. Each is graphically illustrated in the diagram below:

- 1 Fibre Mesh** – the mesh to which the heating cable is fixed to.
- 2 Heating Cable** – a specially constructed cable used for heating.
- 3 Heating Mat** – a heating cable fixed to the fibre mesh.
- 4 Coupling Joint** – the connection between the cold cable and the heating cable.
- 5 Cable termination** – the sealed end of the heating cable.
- 6 Distance between cable loops on a heating mat** – the heating cable is fixed to the fibre mesh at set distances ensuring set outputs per m².
- 7 Cold cable** – the power cable which feeds the heating cable.
- 8 Heated Area** – the area physically covered by the heating mat.
- 9 Thermostat** – an electronic device which enables the on/off switching of the heating mats. It allows control of the floor temperature and the power supply by means of a temperature sensor.
- 10 Floor Temperature Sensor** – a sensor cable which is connected to the thermostat. It has a temperature-sensitive element for measuring the floor temperature and is laid next to the heating mat.

Air Temperature Sensor – an electronic device with a temperature-sensitive element for measuring the air temperature.

Floor Sensor Conduit – this conduit not only protects the floor temperature sensor but if the floor sensor ever fails, the floor sensor may be removed and replaced without having to lift the floor.

2. CAUTIONS

Read these cautions carefully **BEFORE** you start the installation. You must carefully follow the warnings and instructions in this instruction manual. If the Underfloor Heating System is damaged, not installed properly or has restricted air flow causing thermal blocking then fire or shock could occur resulting in serious personal injuries or damage to property.

Always...	Never...
Ensure that all electrical work is executed by a qualified and registered person in accordance with the local building and electrical codes.	Cut the heating cable. The cold cables may be cut shorter if necessary, but not removed completely.
Record the mat and sensor resistance readings and location in the Log before and after the installation. This log, illustration and warranty certificate must be returned to validate the warranty.	Attempt to repair the heating cable if damaged. Contact the Company representatives for instructions before you proceed.
Wear soft elastic sole shoes or cover the mat surface with plywood boards or other material to protect the matting from damage.	Splice one mat heating cable to another to extend the mat. Multiple mats must be connected in parallel via a junction box.
Pay close attention to the voltage and amperage requirements of the breaker, the control, and the heating mat.	Install one mat on top of another one, or overlap the mat on itself. This will cause dangerous overheating.
Avoid heating mat contact with corrosive, hygroscopic, or flammable material. The heating mat must not be exposed to oil, lubricant, solvent etc or similar substance influence.	Remove the name plate label of the mat power leads.
Connect the heating mat earth conductor to the earth terminal in the junction box or to the appropriate thermostat terminal.	Install Webtech-HP mats in any walls or to heat outdoor areas and stairs.
Install the floor temperature sensor.	Install the mats in a cement-sand layer.
Avoid air pockets and pinholes around the heating cable when using latex based self-leveling compound/ flexible tile adhesive.	Put the system ON when the mats are still rolled/ or before the tile adhesive/ latex based self-leveling compound is fully dry.
Seek help if a problem arises. If ever in doubt about the correct installation procedure, or if the product appears to be damaged, you must contact the official representative of the Company before you proceed with the installation.	Cover the floor surface where heating cable is installed with any high thermal insulation materials (high tog carpets, rugs, flat based furniture, bean bags, blankets etc) this will cause thermal blocking
Use casters on furniture where there is little/no air gap between the final floor covering and furniture. This will stop the build up of heat.	Hammer nails, dowels or screws into the floor surface where the heating mat is installed.
Aim to cover at least 80% floor area to achieve primary heating. Please note, high heat loss rooms may require additional heating regardless of high floor area coverage.	Replace the cold leads, breaking sealed coupling connections, made by the manufacturer.
Use the correct insulation type for under the different floor coverings. (See table in section 5.1)	Plug the heating mats to a power supply of a voltage that is different from the operating voltage which is stipulated in the heating mat specification, marking or packaging.
	Perform the thermostat installation and/or repairs with the power supply ON.
	Install the heating cable beyond an expansion joint. If necessary the heating cable should be installed right up to the joint, but do not bridge the joint.

You must always make sure to check the instructions when using any Latex self levelling compound and flexible tile adhesive as they can vary between manufacturers. Please pay particular attention to the thickness require, expansion gap/strips and primers required.

3. SCOPE OF SUPPLY

This installation manual supports every Webtech-HP heating mat for indoor applications only. For a complete system, a thermostat and floor temperature sensor must be installed in addition to the Webtech-HP heating mat.

3.1 The Webtech-HP Heating Mat

The heating mat is made of a shielded double conductor heating cable which is fixed at set spacing to a fibre mesh.

The heating conductor and screen are connected with two installation wires, designed to connect the heating section to the thermostat and earth.

Various cable sheath colours and markings are used to easily differentiate the heating mats from the multiple sizes available.

Please refer to Section 11.0 for specifications of the heating mats.

The heating mats are manufactured and tested in full accordance with the IEC (International Electro-technical Commission) Global Quality Standards.

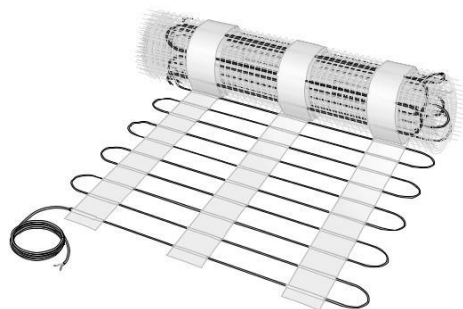

4. ELECTRICAL SAFETY & WALL PREPARATION

All electrical work must be executed by qualified and registered persons in accordance with the local building and electrical codes.

The Webtech-HP system must be connected via a RCD (Residual Current Device) where the actuating rated current does not exceed 30mA. In all instances the earth wire must be connected.

Conductor material	Cross section mm ²	Max. load current A	Max. total load power kW
Copper	2 x 1.0	16	3.5
	2 x 1.5	19	4.1
	2 x 2.5	27	5.9
Aluminium	2 x 2.5	20	4.4
	2 x 4.0	28	6.1

It is important to check that the existing electrical wiring allows sufficient power to the Webtech-HP system. Please refer to Section 11.0 of this manual for the amperage load of the Webtech-HP heating systems. Take into consideration additional electrical appliances which are powered by the same circuit. Furthermore, specify the amperage load of your safety device.

4.1 Electrical Boxes and Trunking

- Choose the thermostat location carefully. It should be installed in the most convenient place, so it will not interfere with furniture or be located in an area where an unfair reading may be obtained. Thermostats which are intended to control the heating in damp premises (bathrooms, toilets, saunas, swimming pools) must be installed outside of such premises.
- Prepare the space for the thermostat mounting and junction box (if required) before laying your underfloor heating system. By doing this first, will ensure that the mats are clear from wall waste and potential damage.
- A 35-40mm back box is required for the fuse spur and a deep back box for the thermostat. Prepare channels in the wall for power supply wires, mat cold leads and temperature sensor in the wall.

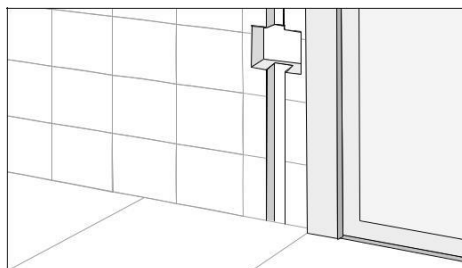

5. INSTALLATION PROCESS

Before opening the packaging of your underfloor heating mat, in all cases, you must re-measure the room to ensure all specified mats will fit and that no errors have been made during the process of room measurement. If a design has been provided, thoroughly check it - mats in opened packaging can not be returned unless faulty.

If you have multiple mats for the same zone then these will be wired in parallel into the thermostat providing they do not exceed the maximum loading. Please ensure you base your layout on the cables being able to return to the thermostat.

5.1 Floor preparation

It is highly recommended that the appropriate insulation is installed to limit heat loss.

Please refer to the table below for information on which insulation to use:

Insulation Type	Suitable Subfloor
Insomax Insulation	Concrete
Ultra Tile Backer Board (with cement layer on both sides)	Any Subfloor

Over Wood Sub-Floors

- Prepare your sub-floor by making sure the area is dry, level, rigid, free from dust/ dirt, secure, with adequate insulation and has an appropriate bearing capacity and suitable for tiling.
- If using Ultra Tile backer board with cement layer, use a notched trowel to apply the flexible tile adhesive (min 10mm) to fix the boards in a staggered pattern to the entire sub-floor. There should be no air gaps/ void underneath the insulation boards once the adhesive is dry, the boards must then be secured with screws and washers (approx 15 per board) at a distance of 30mm from the edge.

Over Concrete Sub-Floor

- Prepare your floor by making sure the area is dry, level, rigid, free from dust/ dirt, secure, and has an appropriate bearing capacity.
- Regardless which type of insulation board is being used, use a notched trowel to apply the flexible tile adhesive to fix the boards in a staggered pattern to the entire sub-floor. Tape all the joints with fibre industrial duck tape. There should be no air gaps/ void underneath the insulation boards.

If you choose to install the heating mats directly onto the existing sub-floor please note:

- The warm up time of your system will be considerably longer than without insulation.
- Ensure the sub-floor is suitable for tiling.
- The sub-floor must be primed with a deepened earth solution. Intensive absorbing surfaces should be primed twice. Allow the surface to fully dry before continuing with the install. If the primer hasn't made the floor tacky it is advised that you spray the floor with a suitable spray adhesive to help the mat adhere to the floor.

Over Ultra Backerboard

You cannot prime the surface of a concrete backer board so it is advised to tackify with a suitable spray adhesive.

Over Insomax XPS insulation

Spray adhesives are not suitable for use over the Insomax board and the mats generally adhere to well to them.

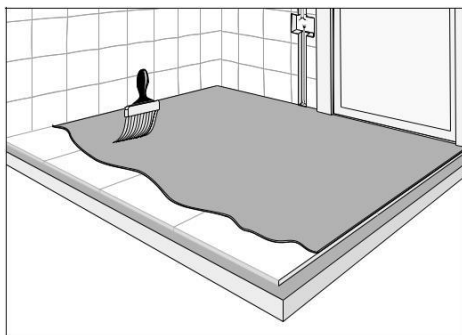

5.2 Testing the Mats

Throughout the installation process, it is essential that an insulation test of the mat and resistance readings of the mat and floor temperature sensor are recorded to ensure they have not been damaged. Use a quality digital* ohmmeter (multi-meter) able to measure up to 20,000 Ω .

Required Measurements

Take and record in the Mat Resistance Log the continuity resistance and insulation readings:

- Before beginning the installation
- After the mat and sensor are fastened to the floor

It is advised that these measurements are also checked frequently during tiling to avoid burying a damaged heating cable or floor temperature sensor.

If the resistance differs from the readings in Section 11.0, contact Rayotec for further instructions. If the heating cable has been cut/sliced or damaged in anyway, clean the damaged area quickly and contact Rayotec for further instructions.

To validate the Warranty, send a copy of the floor heating mats resistance log, Warranty Certificate and mat layout diagram to Rayotec Ltd.

Mat leads resistance check - Measuring between the blue and brown leads of the cold lead.

Mat insulation resistance - Measuring between the two conductors (blue and brown wires) and shielding.

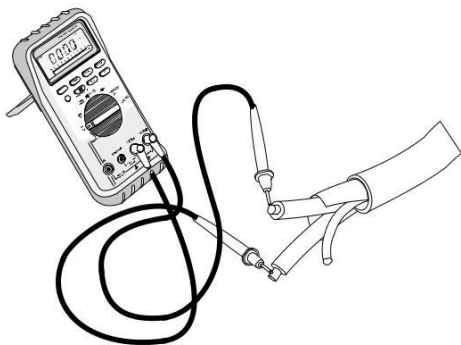

5.3 Important information before laying the mats

Any competent persons can lay the Webtech-HP heating mats using this manual. All electrical work/wiring however, must be completed by a certified electrician who will do the works in accordance with the local building and electrical codes.

- Before laying the mats, check there is no dust or sharp objects on the floor that could potentially damage the heating cable.

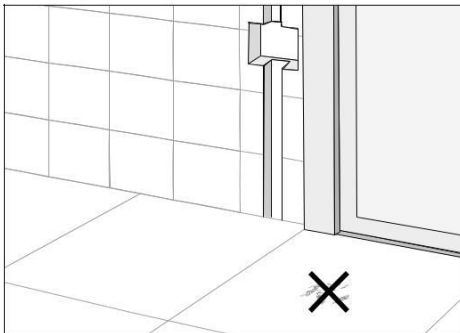

- Mat should be installed a minimum of 8cm from wall perimeter.
- Cable should be installed in meandering fashion so equally spaced. The distance between cables should be no less than 5cm.
- Lay the heating mat on areas free of fixed furniture (i.e. kitchen units, toilets, baths etc).
- Install the mat 10-15 cm away from walls, showers, tubs, and wax toilet rings. You can install right up to vanities and counter areas. The heat will radiate only about 4-5 cm from the heating wire.
- Install the heating mat at a minimum of 10cm away from other heating appliances, e.g. risers and tubes of the water heating system.
- To fit the mat into the heating area, it may be necessary to cut the fibre mesh into fragments. Take care to not cut or damage the heating cable.
- Please note, it is not recommended to use the same mat for heating different types of rooms (e.g. bathroom, hallway or kitchen). It is also not recommended to use the same mat for the heating of rooms with different floor coverings. For this purpose independent mats and corresponding thermostats should be installed.
- You may require additional tape to keep the heating mat down – use either duck tape or double sided tape along the edge of the mat.

*Analog meters are not accurate enough.

5.4 Laying the mats

- Start laying the heating mat close to the thermostat with the cable face up on to the insulation/ sub-floor. The mats include 3 strips of double sided tape please ensure that the backing of the adhesive strips are removed and the adhesive side is laid onto the subfloor or insulation. Please note that failing to remove these may cause issues with latex bonding.

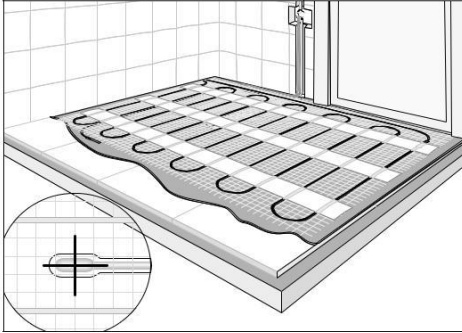

- If you find that you have too much heating mat for your allocated heating area, remove the heating cable from the fibre mesh and lay the heating cable closer together (minimum allowed distance is 6cm apart.) Please note in doing this, this area will be warmer than where the heating cable is still on the fibre mesh.
- Once you have completed laying the mats, sketch a diagram of the heating mat in Section 13.0 and show the location of the coupling joint and temperature sensor location into the premises plan found at the back of this manual. If multiple mats were used, ensure that the mat cold cables are labeled with their mat size so you are able to refer back to them at a later date.
- Please note that while we provide cloth tape you only need to use this sparingly. Any excessive use may affect the ability for the latex or tile adhesive to stick down and could cause cracking in the flooring.

Heating mat placement example:

- Heating area size estimation. Estimate the size of the heating area and choose an adequate heating mat. Adjust the mat to the heating area configuration.
- First cut the mesh of the mat (Ensure to not cut the cable)
- Turn the mat 90° & cut the mesh for the second time
- Flip the mat 180°.
- Heating mat after installation.

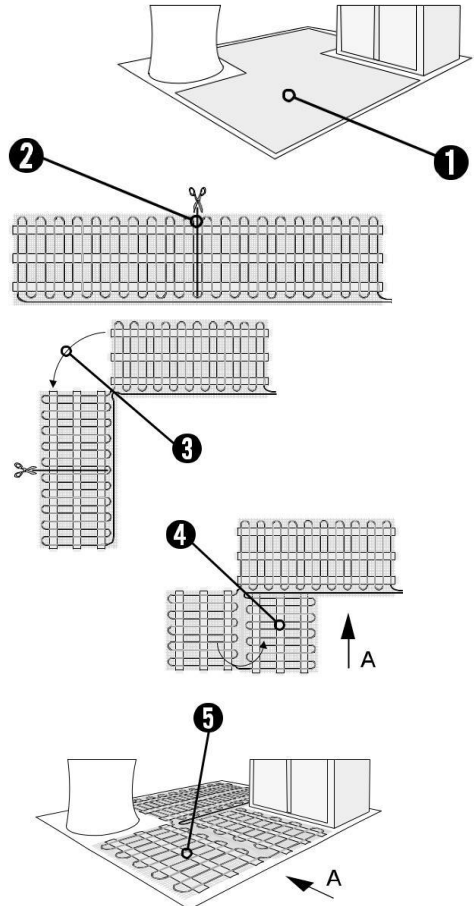

5.5 Installing the conduit, floor sensor (provided with the thermostat) & heating mat cold cable.

1. At this stage you should have already appropriately positioned the thermostat, installed the back box and trunking. If not –please refer to section 4.1- Electrical boxes and trunking.
2. Cut a channel in the insulation/sub-floor for the floor sensor conduit and a second channel for the cold cable/s. The floor temperature sensor should be placed in the middle of 2 loops of cable a minimum of 2cm from the heating cable either side. It can not touch or cross over the heating cable at any point.

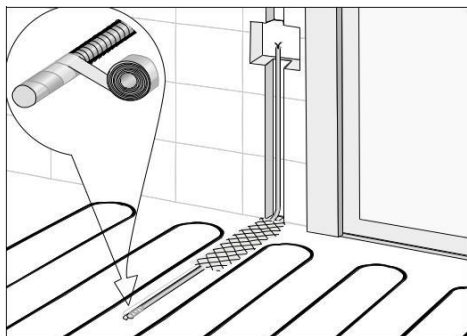

3. Place the floor temperature sensor into the floor sensor conduit. Tape the end of the floor sensor conduit so it is sealed against ingress of adhesive.
4. Place the cold cable and conduit with floor sensor in their appropriate channel.

The conduit bending radius must be a minimum of 5cm and as smooth as possible. When the corrugated tube is affixed to the wall and the floor, make sure that the sensor floats inside the tube. For this, pull the floor sensor cable partially out and then insert it back. This installation method allows the replacement of the sensor without removing the floor covering.

Attention: The start of the floor sensor conduit with the sensor cable should be at the terminal box or the thermostat. This will allow you to replace the sensor cable without removing the floor covering if required.

5. Check that the heating mat and temperature sensor cable were not damaged during the install by performing an insulation test of the heating mat and resistance reading of the heating mat and temperature sensor. This reading should conform to Section 11.0 and logged in Section 12.0.

Please note if self-levelling is not carried out directly after laying the heat mat there is the possibility that cables will rise due to the heat mat losing its adhesiveness over time. This will vary depending on time of the year and air temperature within the room. Please ensure the heat mat is checked and taped/glued down adequately as if it is not further skims of self-levelling may be required

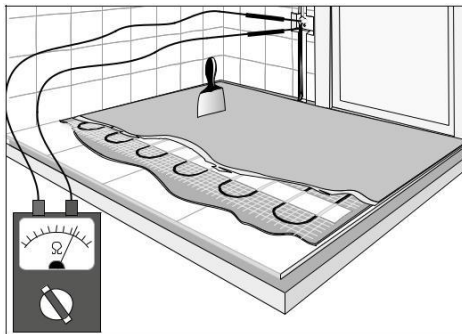

6. WIRING THE WEBTECH-HP HEATING SYSTEM

WARNING! It is essential that the power from the fuse box or electrical source is switched off before beginning to work.

Multiple mats may be run in parallel into the thermostat providing they do not exceed the maximum loading

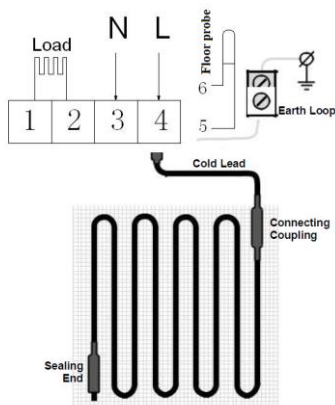

For the correct connection of the Webtech-HP mat, please, pay attention to the colours of the installation wires. The blue and brown/black (live) installation wires are connected to the thermostat. The earth wire must be connected to the earth.

1. Connect the floor temperature sensor and cold cable of the heating mat directly to the thermostat. If multiple mats are used, the cold cables must be connected in parallel to the thermostat via the junction box. (All junction boxes must be placed where they are accessible after the installation is finished.)

Please consult your electrician to calculate how much can be connected to any one thermostat. If the total amperage of the system is greater than the amperage of the single thermostat, the system will either require a separate thermostat or a contactor to break the current. (See section 6.1 for further information on contactors).

2. Connect the earth wire to the earth.
3. Connect the electric power to the thermostat and perform earthing. Please refer to the thermostat installation manual of how it should be connected.
4. Fill the chiseled channels in the wall, which lead the connection wires, earth circuit, cold leads and the temperature sensor wires in the corrugated tube.

5. Lay your final floor covering according to its own instruction manual.

6. Use of Contactors

If the total amperage of the system exceeds the amperage on the thermostat, then either an additional thermostat or a contactor must be installed. Using a contactor will enable you to break the current and use a single thermostat. A contactor can be supplied and installed by your local electrician *e.g. If your heating system requires 16.5 amps, the system will require either an additional thermostat or a contactor as a thermostat normally works up to a maximum of 16amps (please check with the thermostat manual what your maximum amperage is).*

7. FLOORING TYPES

Floor Type	Restrictions
Under Tiles	Thickness allowed: 5mm-30mm

Although it is possible to tile straight onto the mat, you will find it difficult to attain a good finish. We strongly recommend covering the mat with a minimum of 10mm of flexible self-levelling compound. The depth is dependent on the floor build up, brand of adhesive used and final floor covering so ensure you check with the adhesive manufacturer for the required depth. The maximum thermal resistance between the heating mat and the premises, produced by the adhesive layer and ceramic tile, should not exceed 0.06 m²K/W.

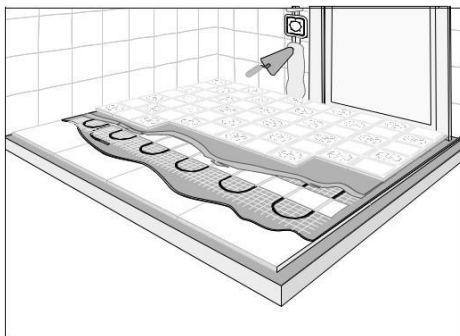

Under carpet, wood, vinyl, Amtico and Karndean we recommend using a 150W/m² matting.

Under any floor covering:

The insulation boards are a rigid and dense foam board. If you receive anything other than this ie a roll of insulation foam you may have been sent the wrong product so please contact us before laying the system.

INSTALLATION UNDER TILE FLOORING

- 1 Tiles fixed down using flexible tile adhesive
- 2 Flexible self-levelling compound
- 3 Heating Cable Mat
- 4 Insulation Board
- 5 Flexible Tile Adhesive
- 6 Floor Slab

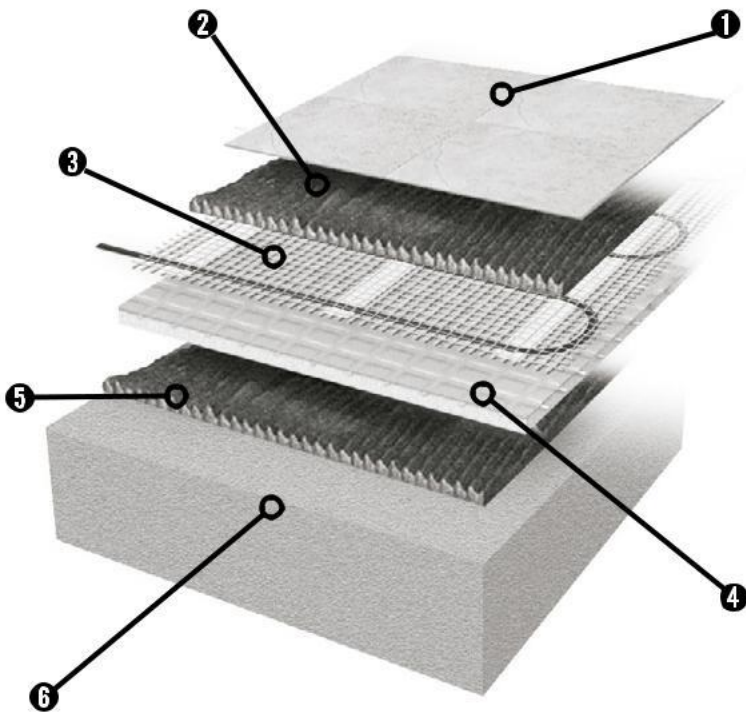

8. SWITCHING THE SYSTEM ON AND MAINTENANCE

The underfloor heating system can be switched on after the flexible tile adhesive/ latex based self-leveling compound is fully dry. (Please refer to adhesive drying times).

The heating should be turned up by 1°C every 2 days to allow the flooring to acclimatise and avoid damage.

When the temperature reaches the comfort level, you can reduce the heating level as desired. When the system is turned on for the first time, the “warm floor” feeling will appear after some time.

If you vacate your premises during the cold season, do not switch the system off. Set the thermostat on the minimal level so that the power consumption is minimal and the room will not be cooled down completely.

9. TROUBLESHOOTING TIPS

If the overall floor surface feels unusually cool after the system has been energized for more than 8 hours, verify that the heating controller is correctly installed and functioning properly; check with the associated heating controller's operating manual and/or contact the manufacturer. If the overall floor surface feels unusually hot when the system is energized, or if the circuit breaker trips when the system is energized, the cable may be damaged. Turn-off the system immediately and contact the manufacturer for assistance.

Note: In the event that the heating cable has been damaged, the fault may typically be located and field repaired with minimal flooring removal.

10. WARRANTY DETAILS

The manufacturers provide a 16-year warranty for the heating mats for the first and documented installation. Any removal, modification of the floor, secondary installation will invalidate the warranty. They guarantee that the Products are free from defects in materials and workmanship.

The warranty is void if there is any payment default.

During the warranty period we are obligated to repair the heating mat or the heating cable or to deliver a new one to the customer free of charge. **We are not obligated to cover the indirect costs, which are connected to the repair works or replacement of the heating mat or the heating cable.**

Terms of Warranty:

The heating sections (mats and cables) are to be used strictly in accordance with the appropriate Installation Manual. For the warranty to be valid, both the Resistance Log Data and Warranty Certificate must be sent back to Rayotec Ltd within 30 days from date of purchase. If the appropriate information has not been sent, the warranty will automatically become null and void. In any case that the mat must be returned, the following information is required:

- The reason of the dissatisfaction of the customer in written form, a written description of the Product installation works and the history of operation.
- The customer has also to provide a retail sales receipt or another proof of purchase of the heating system.

The company retains the right to decide on the basis of the submitted documentation or after the preliminary diagnostics of the heating systems by the Company specialists.

The following are not covered by this Warranty:

- Any incidental or consequential damage, including inconvenience, loss of time or loss of income.
- Any labor or materials required to remove, repair or replace flooring materials.
- Any freight or delivery costs related to the Product, the control, or any related flooring or electrical products.

There are no warranties which extend beyond the face of this document. Our Company further disclaims any responsibility for special, indirect, secondary, incidental or consequential damages which arise from the ownership or use of this product, including inconvenience or loss of use. No agent or representative of our Company has any authority to extend or modify this Warranty unless such extension or modification is made in writing by a Company officer. Due to differences in building and floor insulation, climate and floor coverings, our Company makes no representation that the floor temperature will achieve any particular temperature, or temperature rise. But our Company does warrant that all Products will produce rated output listed in the Heating Mat Specification (Section 11).

Products that have been damaged due to mechanical breakdown, due to incorrect connection or due to disregard of the terms of operating rules and servicing are not a subject to the warranty repairs, replacement or return.

The thermostats have a 1 year warranty where the same Terms and Conditions stated above apply.

All claims are to be sent to the following address:

Rayotec Ltd. Unit 5 Trade City Sunbury, Brooklands Close, Sunbury-on-Thames TW16 7FD

11. WEBTECH-HP HEATING MAT SPECIFICATION

Double-conductor heating mats - 200W/m²

Type	Width (m)	Length (m)	Power- W (230V)	Resistance Ohms
Webtech-HP – 1.0m ²	0.5	2	200	264.5
Webtech-HP – 1.5m ²	0.5	3	300	176.33
Webtech-HP – 2.0m ²	0.5	4	400	132.25
Webtech-HP – 2.5m ²	0.5	5	500	105.80
Webtech-HP – 3.0m ²	0.5	6	600	88.17
Webtech-HP – 3.5m ²	0.5	7	700	75.57
Webtech-HP – 4.0m ²	0.5	8	800	66.13
Webtech-HP – 4.5m ²	0.5	9	900	58.78
Webtech-HP – 5.0m ²	0.5	10	1000	52.90
Webtech-HP – 6.0m ²	0.5	12	1200	44.08
Webtech-HP – 7.0m ²	0.5	14	1400	37.79
Webtech-HP – 8.0m ²	0.5	16	1600	33.06
Webtech-HP – 9.0m ²	0.5	18	1800	29.39
Webtech-HP – 10.0m ²	0.5	20	2000	26.45
Webtech-HP – 12.0m ²	0.5	24	2400	22.04

Minimum subfloor temperature should be +5°C. The minimum mat installation temperature is -5°C.

Floor Temperature sensor cable 8 - 15kohms. Please note that the readings must be done by a qualified electrician using a multifunction tester or fluke tester, a basic multimeter may give inaccurate or varying results, this is normal and must be double checked by a qualified electrician.

12. MAT AND TEMPERATURE SENSOR RESISTANCE LOG (COMPLETED BY A QUALIFIED ELECTRICIAN)

Cat. Ref. & Sr No.	Test	Before Installation	After installation but before laying tiles	After laying tiles
	Resistance of cables (Ohms)			
	Installation Resistance (M.Ohms)			
	Continuity			

If more than 2 Mats are used please copy this page and continue logging.

DO NOT DISCARD!

To validate your warranty, copy of this log must be sent to Rayotec along with your warranty certificate and mat premises plan

13. MAT PREMISES PLAN

The plan of the premise where the location of the thermostat, the heating mat, the couplings, the end muffs and floor temperature sensor are indicated.

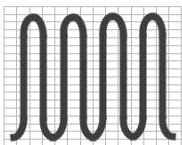
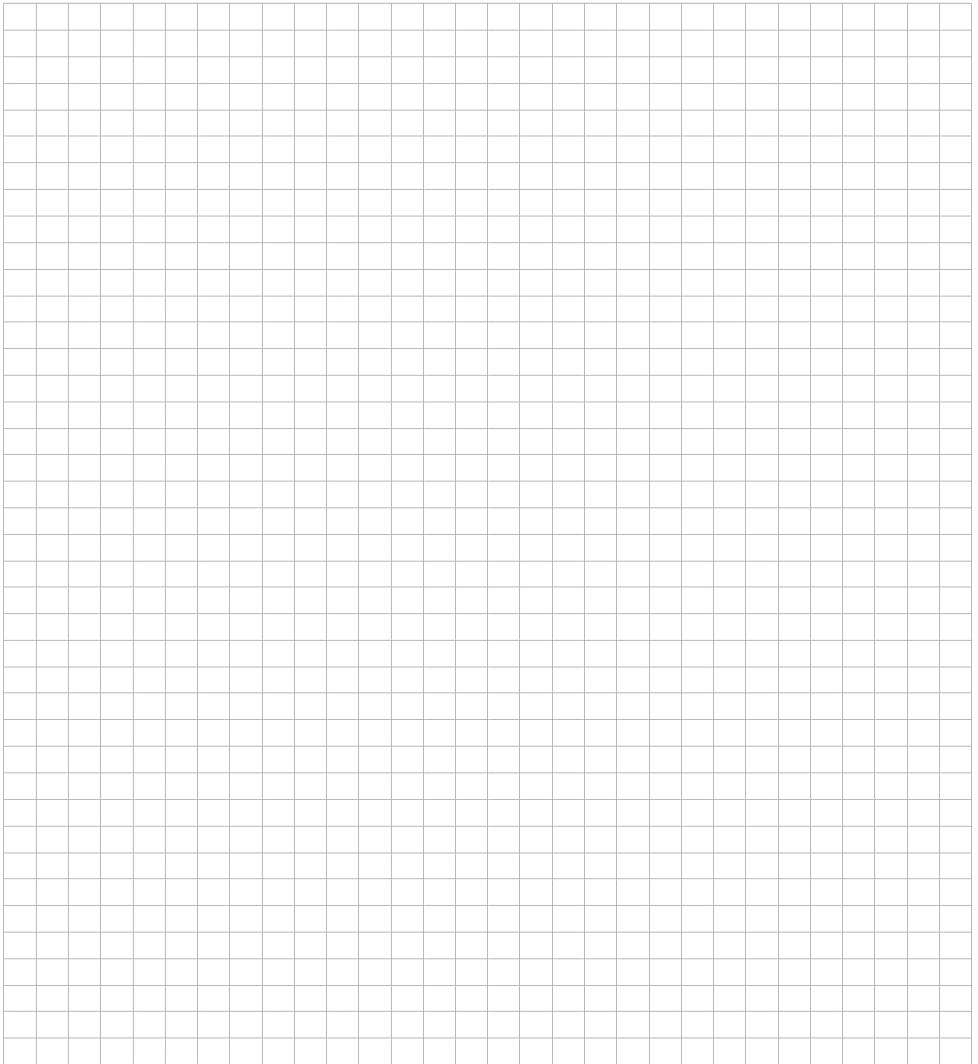

Heating mat

Temperature sensor tube

Legend



Thermostat



Coupling



Temperature sensor



End muff

14. WARRANTY CERTIFICATE

Full Name.....

Street.....

City..... Post Code Telephone

Country.....

E-Mail.....

Purchased from..... Invoice No.....

City.....

Installer name..... Date of Purchase.....

Please state the rooms Webtech-HP is heating: Rm1..... Rm2..... Rm3.....

Total floor area in each room: Rm1..... m₂ Rm2..... m₂ Rm3..... m₂

Total area of matting installed in each room: Rm1..... m₂ Rm2..... m₂ Rm3..... m²

If there are more than 3 rooms please copy this page and record the other rooms.

Please state the mat sizes along with their serial number which is found on the plastic packaging of the mat:

Room 1: Mat size/s:..... m₂ Webtech-HP Mat - Mat Serial Number /s:.....

Room 2: Mat size/s:..... m₂ Webtech-HP Mat - Mat Serial Number /s:.....

Room 3: Mat size/s:..... m₂ Webtech-HP Mat - Mat Serial Number /s:.....

If there are more than 3 rooms please copy this page and record the other rooms.

Thermostat (Digital or Dial)

Thermostat (Model Number)

Corrugated tube Installed? Yes..... No..... (Please tick appropriate box)

Insulation Installed? Yes..... No..... (Please tick appropriate box)

I have fully read and understood all stated in the installation manual:

Customer (signature)

The installation was performed by..... Date..... 20.....(signature)

Part P Number of Electrician.....

Please complete & send/fax/email back with the Mat And Temperature Sensor Resistance Log (section 12.0) to:

Rayotec Ltd • Unit 5 • Trade City Sunbury • Brooklands Close Sunbury-on-Thames • TW16 7FD

Fax : 01932 784 849 • Email: info@rayotec.com

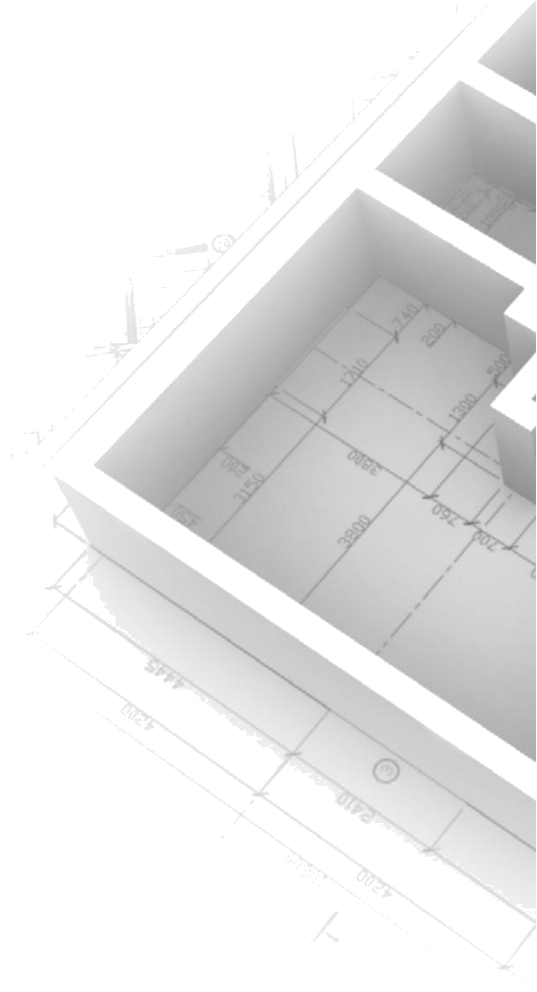

Rayotec Ltd • Unit 5 • Trade City Sunbury • Brooklands Close • Sunbury-on-Thames • TW16 7FD
Tel : 01932 784 848 • Fax : 01932 784 849
www.rayotec.com